

September 19, 2011

Copyright Technology 101

U.S. Patent and Trademark Office (USPTO) Global Intellectual Property Academy and U.S. Copyright Office

Conference on Copyright in the Digital Age

Presenter:

Daniel Castro, Senior Analyst, ITIF



Overview

How does the Internet work?

Who governs the Internet?

Who is part of the Internet ecosystem?

How does the Internet work?

Typical view of the Internet:

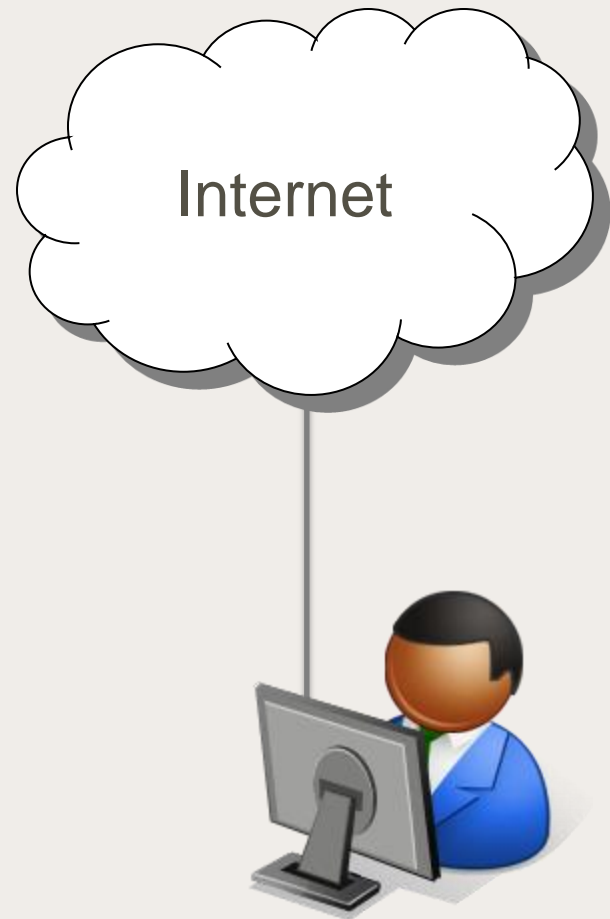

How does the Internet work?

More detailed:

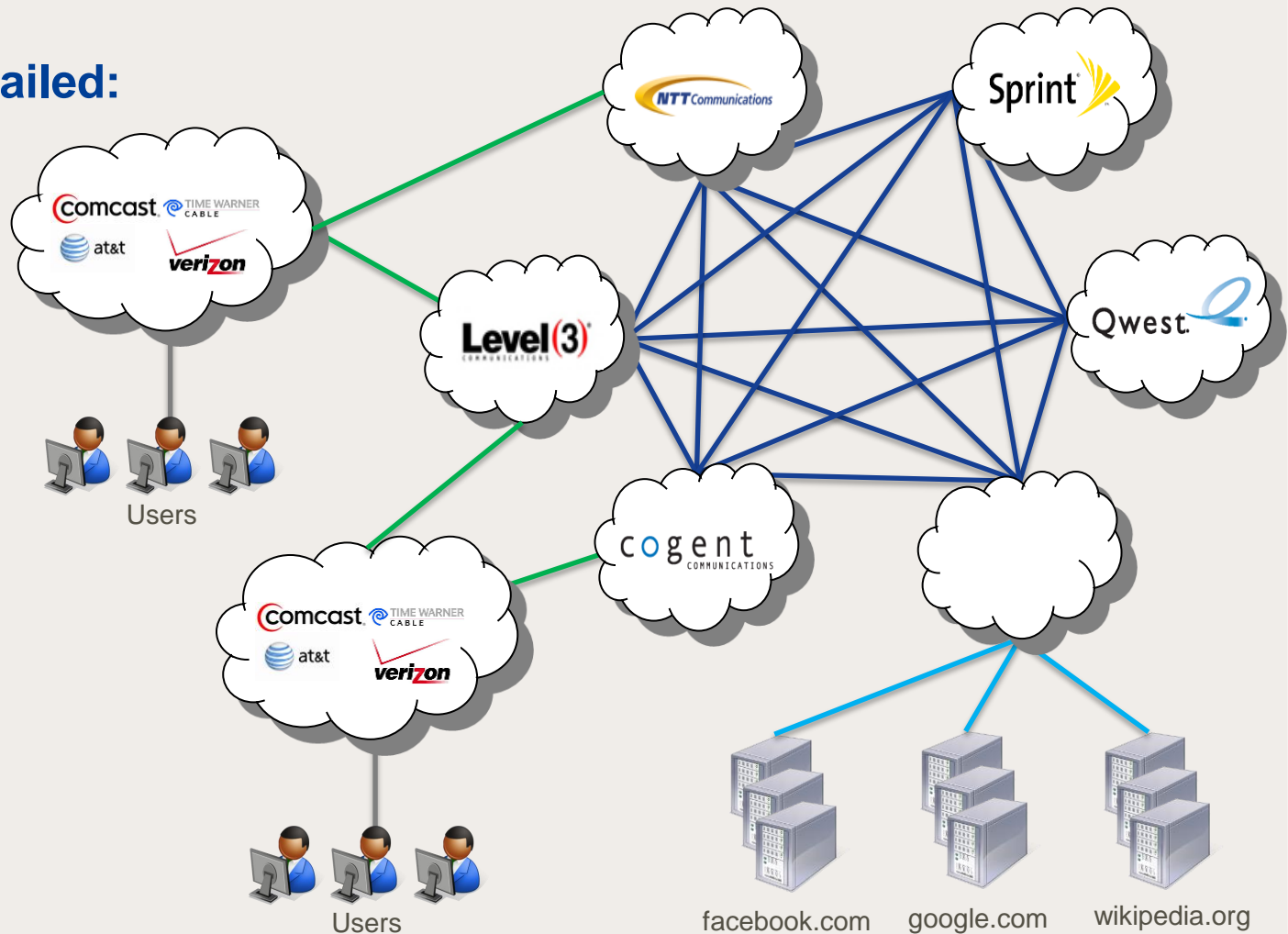

How does the Internet work?

URLs:

http://www.nytimes.com/tech/index.html

application
transfer
protocol

host
name.

domain
name.
top-level
domain

path

file

case sensitive

Image credit: John Gallaugher, *Information Systems: A Manager's Guide to Harnessing Technology* (Flat World Knowledge).

How does the Internet work?

Domain names:

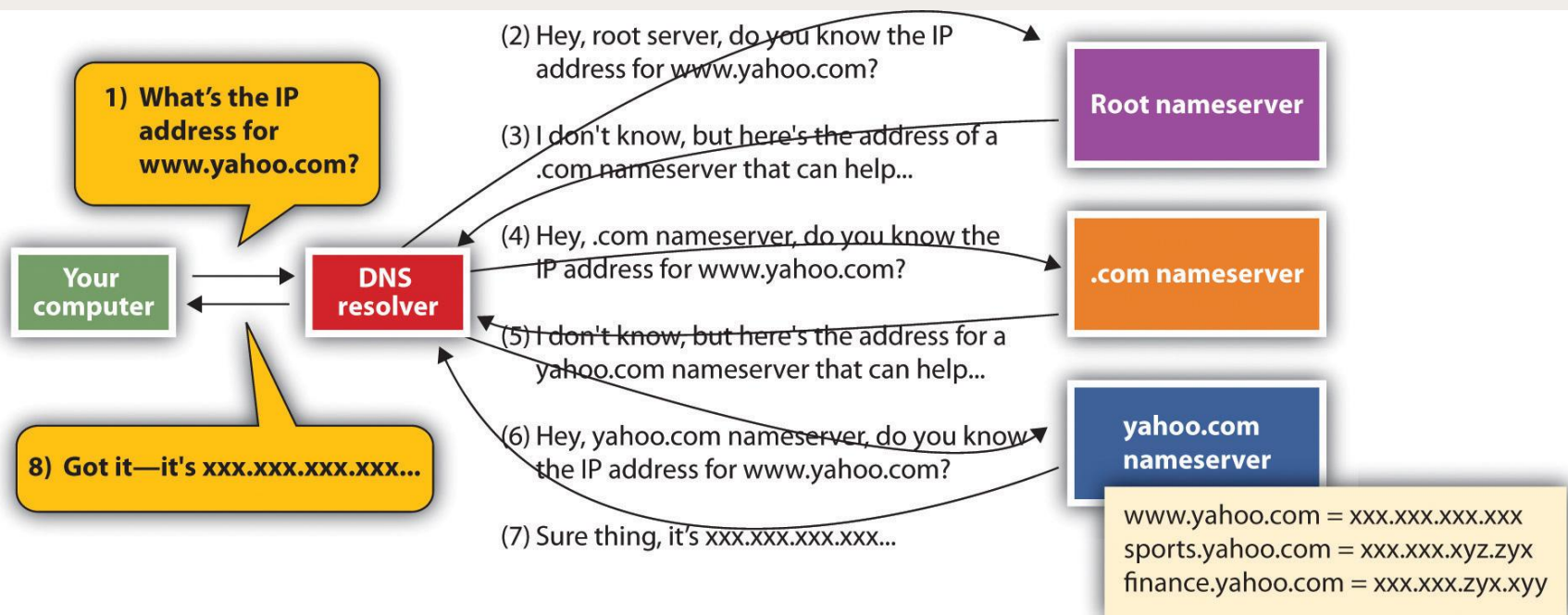

Image credit: John Gallaugher, *Information Systems: A Manager's Guide to Harnessing Technology* (Flat World Knowledge).

How does the Internet work?

Data Packets:

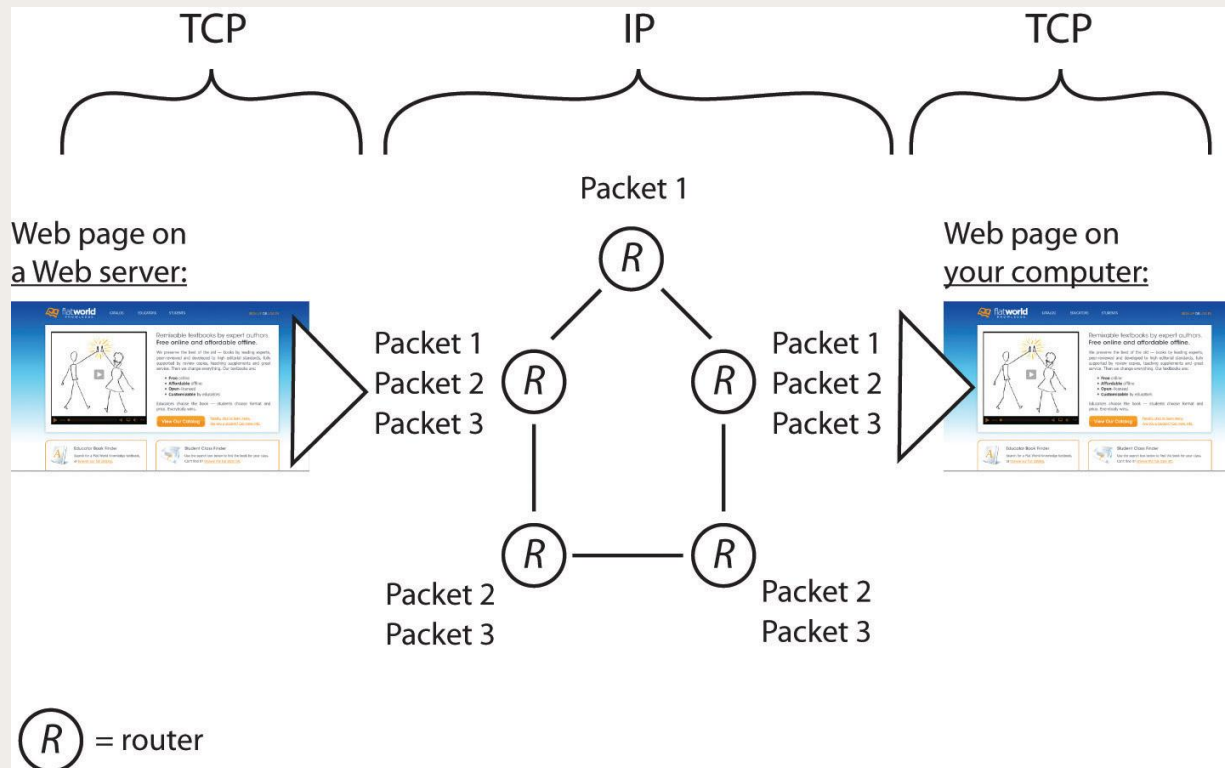

Image credit: John Gallaugher, *Information Systems: A Manager's Guide to Harnessing Technology* (Flat World Knowledge).

Who governs the Internet?

Nobody?

Who governs the Internet?

At the National Level (in the United States)

- Federal Communications Commission (FCC)
 - Net neutrality rules
- National Telecommunications and Information Administration (NTIA)
 - Broadband, spectrum, DNS, privacy/security/copyright issues
- Federal Trade Commission (FTC)
 - Anti-trust and consumer protection
- Department of Justice
 - Internet crime
- Congress
 - Legislative authority

Who governs the Internet?

At the International Level

- **Coordination and operations**
 - ICANN
- **Standards**
 - Internet Society (ISOC)
 - Internet Engineering Tasking Force (IETF)
 - Internet Architecture Board (IAB)
 - World Wide Web Consortium (W3C)
 - International Telecommunication Union (ITU)
- **The Market**
 - E.g. Mozilla Foundation, Verisign

Who is part of the Internet ecosystem?

- **Users**
- **Internet service providers**
- **Domain registrars**
- **Domain registries**
- **Hosting providers**
- **Governing bodies**

- **OTHERS?**
 - **Services:** search engines, file lockers, UGC sites, online advertisers, payment processors, shippers
 - **Applications:** operating systems, web browsers, software
 - **Devices:** mobile devices, computers, routers, etc.

Who is part of the Internet ecosystem?

Questions:

- **Where are the “control points” on the Internet?**
- **How can different methods be used to protect intellectual property at these different points?**
- **Who has a legal responsibility to protect intellectual property?**
- **Who would be most effective in protecting intellectual property? (and what incentives do they need, if any, to do so?)**

Further reading

**Castro, Bennett and Andes, “Steal these Polices: Strategies for Reducing Digital Piracy,” Information Technology and Innovation Foundation (December 2009),
<http://www.itif.org/files/2009-digital-piracy.pdf>.**

**Castro, “Better Enforcement of Online Copyright Would Help, Not Harm, Consumers,” Information Technology and Innovation Foundation (October 2010),
<http://www.itif.org/files/2010-copyright-coica.pdf>.**

**Price, “An Estimate of Infringing Use of the Internet,” Envisional (January 2011),
http://documents.envisional.com/docs/Envisional-Internet_Usage-Jan2011.pdf.**

Thank you!



Email: dcastro@itif.org
Twitter: [@castrotech](https://twitter.com/castrotech)
Web: www.itif.org